

Annexure-A**Details of HSFG Bolts (Gr.10.9) with & without CSK**

Sl. No.	Size	Qty	Unit
1	M20 x 50 HSFG Bolt	4830	Sets
2	M20 x 55 HSFG Bolt	42300	Sets
3	M20 x 60 HSFG Bolt	6400	Sets
4	M20 x 65 HSFG Bolt	2140	Sets
5	M20 x 70 HSFG Bolt (Taper Washer in place of Plain Washer)	1170	Sets
6	M20 x 75 HSFG Bolt	1550	Sets
TOTAL HSFG BOLT (Gr.10.9)		58390	Sets

Sl. No.	Size	Qty	Unit
1	M16 x 62 CSK HSFG Bolt ISMB	3170	Sets
2	M16 x 62 CSK HSFG Bolt ISMC	48610	Sets
3	M16 x 100 CSK HSFG Bolt	408	Sets
4	M22 x 80 CSK HSFG Bolt	408	Sets
5	M22 x 110 CSK HSFG Bolt	816	Sets
6	M22 x 130 CSK HSFG Bolt	216	Sets
TOTAL CSK HSFG BOLT (Gr.10.9)		53628	Sets

THE BRAITHWAITE BURN & JESSOP CONSTRUCTION CO. LTD.

(A Govt. of India Enterprise)

HSFG BOLT ORDER LIST FOR SITE

MADE BY - R. BOSE

CHECKED BY- S. MAJUMDER

DATE - 24.04.23

SHEET NO.- HSFG/2154/SS/01

BBJ'S DRG.NO.-

ORDER NO.- 2154

PROJECT:

**24x76.2 M. SPAN TRUSS GIRDER PROPOSED RAIL BRIDGE OVER RIVER
GANGA BETWEEN JHUSI AND DARAGANG STATION AT ALLAHABAD (U.P.)**

REV.-

DATE:-

Nos. per 1000 pieces In Kgs.	Gross No.	Spare	Net. No.	Bolt Head	Dia	Through	Grip	Thread Length	Length	Nut Head	Position of Work	Weight (Kgs.)	Remarks	
HSFG BOLTS FOR WALKWAY, GANGWAY & TROLLEY REFUGE FOR 24 x 76.2 M SPAN														
	1550			HEX.	22			55	65	HEX.	EACH HSFG HEX. HD. BOLT CONSIST OF ONE DTI WASHER, ONE CHAMFERED WASHER, ONE TAPER WASHER & ONE HEX. HD. NUT.			
	3110			HEX.	22			50	95	HEX.				
	2140			HEX.	22			60	70	HEX.	EACH HSFG HEX. HD. BOLT CONSIST OF ONE DTI WASHER, ONE CHAMFERED WASHER, ONE PLAIN WASHER & ONE HEX. HD. NUT.			
	3200			HEX.	22			50	90	HEX.				
TOTAL=	10000													
	4830			HEX.	20			40	50	HEX.	EACH HSFG HEX. HD. BOLT CONSIST OF ONE DTI WASHER, ONE CHAMFERED WASHER, ONE PLAIN WASHER & ONE HEX. HD. NUT.			
	42300			HEX.	20			45	55	HEX.				
	6400			HEX.	20			50	60	HEX.				
	2140			HEX.	20			55	65	HEX.				
	11060			HEX.	20			46	70	HEX.				
	1170			HEX.	20			46	70	HEX.	EACH HSFG HEX. HD. BOLT CONSIST OF ONE DTI WASHER, ONE CHAMFERED WASHER, ONE TAPER WASHER & ONE HEX. HD. NUT.			
	1550			HEX.	20			46	75	HEX.				
TOTAL=	69450													

NOTE:-

1. ALL HSFG BOLTS ARE CL-10.9 & NUTS ARE 10 (AS PER RDSO.DRG.NO. B-11760/R1) CONFORMING TO IS:4000 (1992) & EN 14399-3.
2. ALL DTI WASHER AS PER EN 14399-9 & PLAIN WASHERS AS PER EN 14399-5 & TAPER WASHER AS PER IS: 5372 & 5374.
3. EACH HSFG HEX. HD. BOLT CONSIST OF ONE DTI WASHER, ONE CHAMFERED WASHER, ONE PLAIN/TAPER WASHER (As Required) & ONE HEX. HD. NUT.
4. ALL BOLTS, NUTS & WASHERS MUST HAVE IDENTIFICATION MARK & MANUFACTURER'S SYMBOL & PROPERTY CLASS.
5. ALL BOLTS, NUTS & WASHERS MUST HAVE MANUFACTURER'S TEST CERTIFICATE IN ADDITION THREE SETS OF RANDOM SAMPLE CONSISTING OF 1 NO. HEX. HD. BOLT+HEX. HD. NUT+CHAMFERED WASHER+PLAIN WASHER/TAPER FROM EACH LOT TO BE SENT TO REPUTED INDEPENDENT NABL ACCREDITED LABORATORY.
6. SURFACE FINISH OF ALL BOLTS, NUTS & WASHERS WITH ZINC FLAKE COATING AS PER ISO 10683 SHOULD BE DONE.
7. BOLT LENGTH WITH RESPECT TO GRIP & OTHER ALL DIMENSIONAL DETAILS TO BE VERIFIED BY THE PARTY PRIOR TO APPROVAL OF MANUFACTURING.

Req No:-

D/2351

Date:

24.04.2023

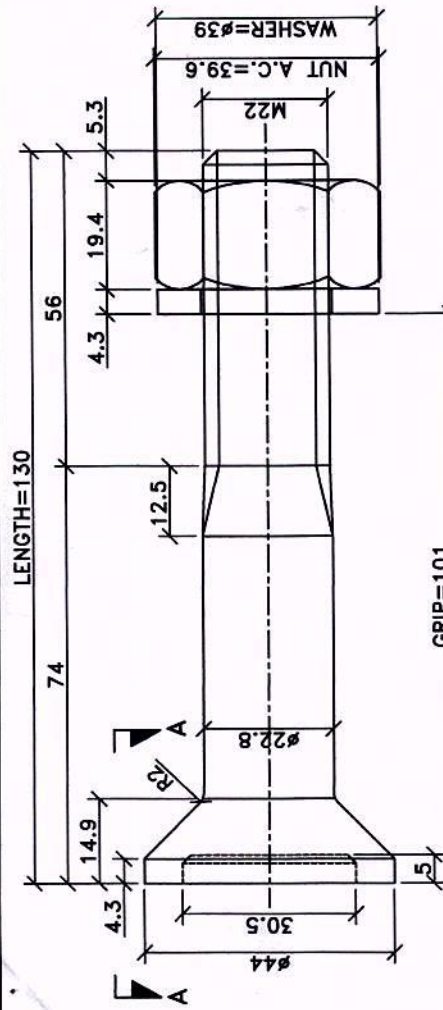

216 NOS. C.S.K. BOLT M22x130 LG. (WITH SPARE)

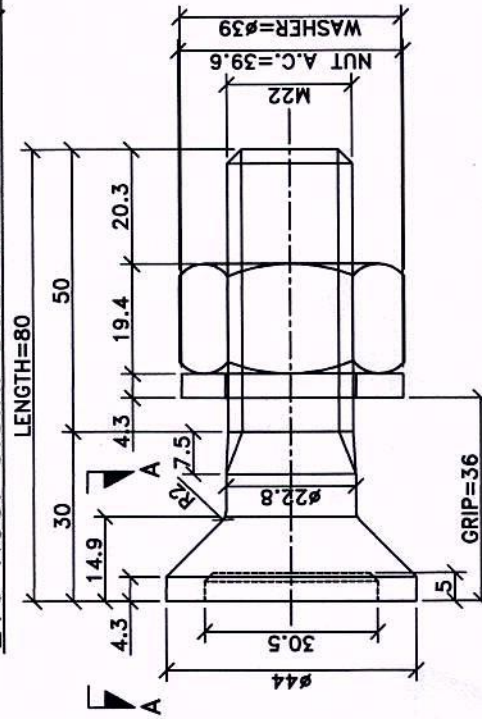

408 NOS. C.S.K. BOLTS M22x80 LG. (WITH SPARE)

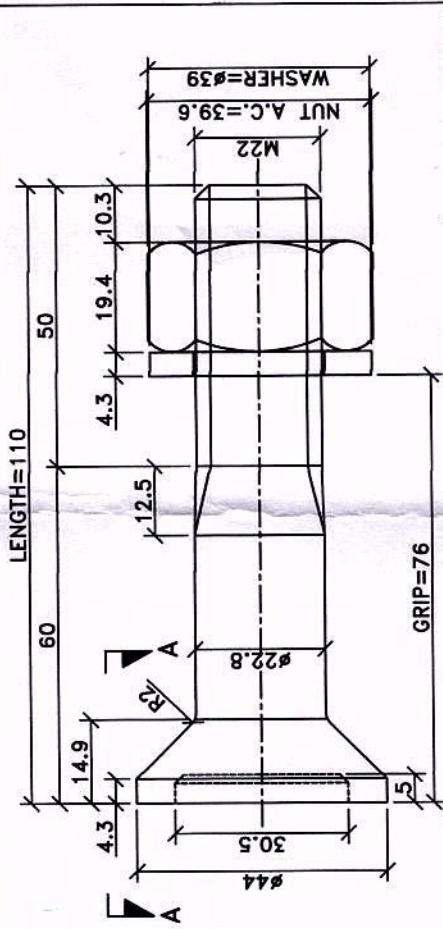

816 NOS. C.S.K. BOLTS M22x110 LG. (WITH SPARE)

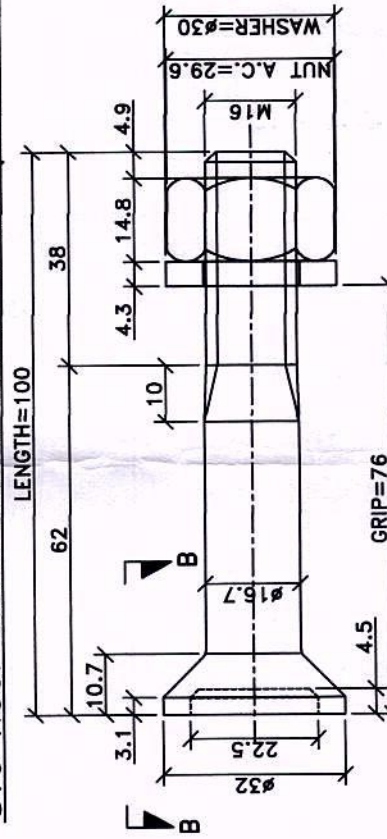

408 NOS. C.S.K. BOLT M16x100 LG. (WITH SPARE)

- NOTE:-
1. ALL DIMENSIONS ARE IN mm.
 2. EACH HSFG. CSK. BOLT CONSIST OF 1 NO. HEX. NUT AND 1 NO. PLAIN WASHER.
 3. HSFG. BOLT CONFORMING TO BS:111 REV.-6 AND EN:14399-3 & 7 GRADE 10.9
 4. THREAD LENGTH OF BOLT WILL BE AS PER EN:14399 PART-7
 5. HSFG. NUT CONFORMING TO EN:14399-3 AND 7 GRADE 10
 6. PLAIN WASHER CONFORMING TO EN:14399-5 EN:14399-5 & IS:1570 LATEST EDITION.
 7. ALL BOLTS & NUTS AND WASHERS SHALL BE COATED WITH ZINC FLAKES AS PER ISO:10683
 8. MARKING ON BOLTS, NUTS & PLAIN WASHER WILL BE AS PER EN:14399 PART-7.

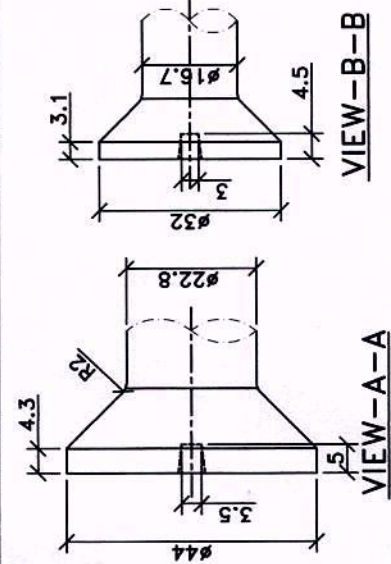

EXECUTION AGENCY:



THE BRAITHWAITE BURN & JESSOP CONSTRUCTION COMPANY LIMITED, KOLKATA
(A GOVT. OF INDIA ENTERPRICE)

OWNER CLIENT:

NORTH EASTERN RAILWAY

CLIENT:

RAIL VIKAS NIGAM LIMITED

PROJECT: 2x76.2 M. SPAN TRUSS GIRDER PROPOSED RAIL BRIDGE OVER RIVER GANGA BETWEEN JHUSI AND DARAGANG STATION AT ALLAHABAD (U.P.)

SCALE:- 1:2.5 NAME DATE TITLE:

DRAWN BY: R. BOSE 12.10.22

CHECKED BY: S.MJUMDER 12.10.22

APPROVED BY:

DETAILS OF C.S.K. BOLTS AT LO JOINT

B.B.J. ORDER NO.- 2154 B.B.J. SKETCH NO.- 2154-SK-01

SHEET SIZE:- A4 REV.

REGN. NO. - D/2351

DATE :- 24.04.2023

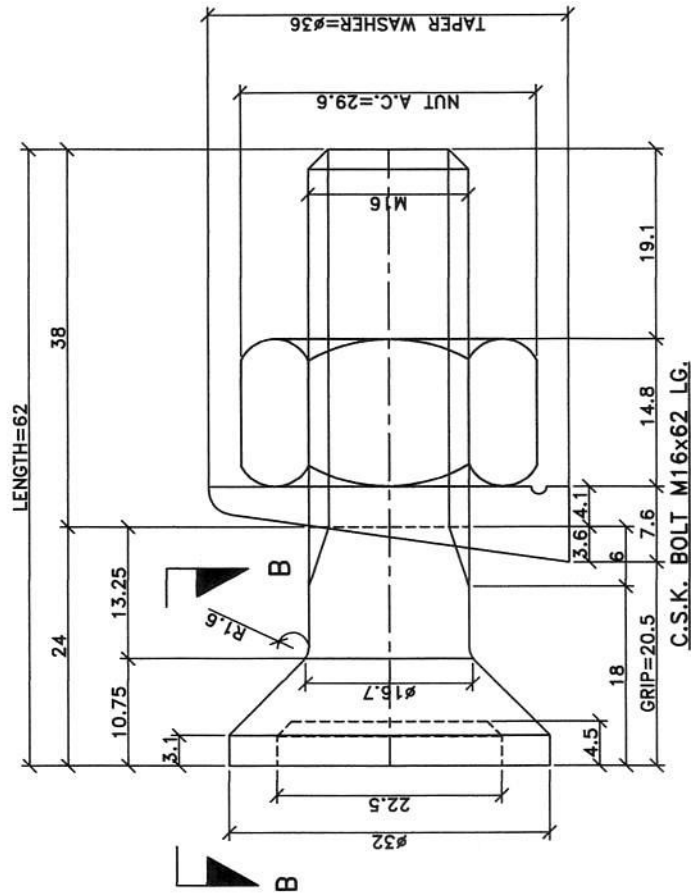

TOTAL NUMBER OF CSK BOLT FOR GANGWAY=(3156+14 NOS. SPARE) 3170 Nos.

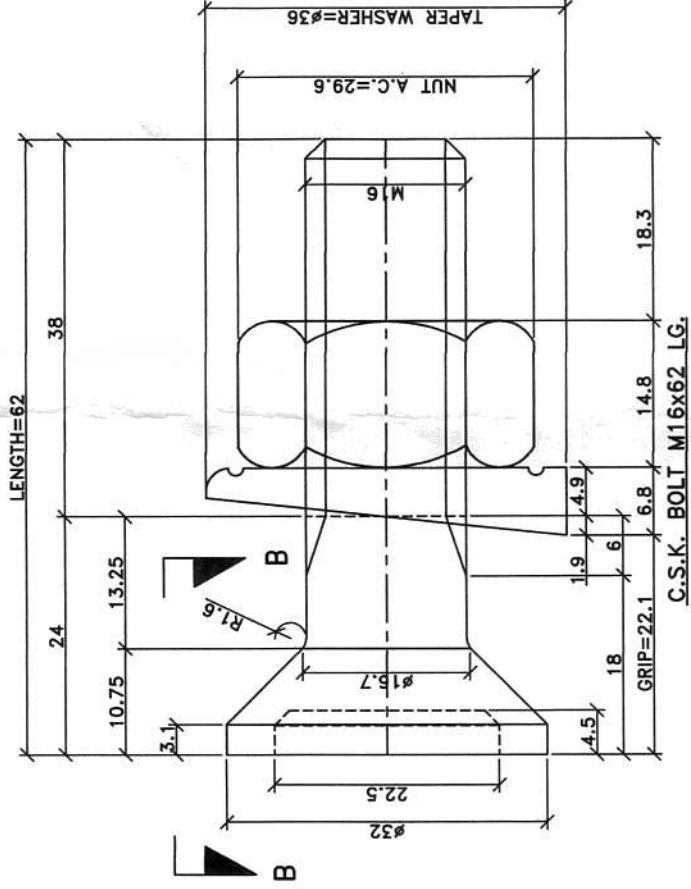

TOTAL NUMBER OF CSK BOLT FOR WALKWAY=(14722+88 SPARE) 14800 Nos.

TOTAL NUMBER OF CSK BOLT FOR TROLLEY REFUGE=(6144+16 NOS. SPARE) 6160 Nos.

TOTAL NUMBER OF CSK BOLT FOR GANGWAY=(27524+126 NOS. SPARE) 27650 Nos.

NOTE:-

1. ALL DIMENSIONS ARE IN mm.
2. EACH HSFG, CSK, BOLT CONSIST OF 1 NO. HEX. NUT AND 1 NO. PLAIN WASHER.
3. HSFG, BOLT CONFORMING TO BS:111 REV.-6 AND EN:14399-3 & 7 GRADE 10.9
4. THREAD LENGTH OF BOLT WILL BE AS PER EN:14399 PART-7.
5. HSFG NUT CONFORMING TO EN:14399-3 AND 7 GRADE 10
6. TAPER WASHER CONFORMING TO IS:5372 FOR ISMC AND IS:5374 FOR ISMB.
7. ALL BOLTS & NUTS AND WASHERS SHALL BE COATED WITH ZINC FLAKES AS PER ISO:10683
8. MARKING ON BOLTS, NUTS & PLAIN WASHER WILL BE AS PER EN:14399 PART-7.

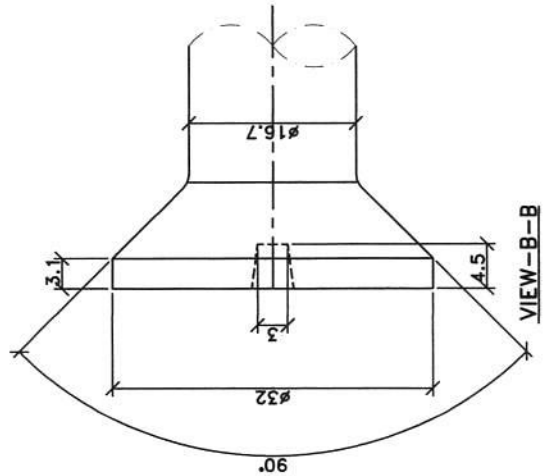

EXECUTION AGENCY:



THE BRAITHWAITE BURN & JESSOP CONSTRUCTION COMPANY LIMITED, KOLKATA
(A GOVT. OF INDIA ENTERPRICE)

OWNER CLIENT: **NORTH EASTERN RAILWAY**

CLIENT: **RAIL VIKAS NIGAM LIMITED**

PROJECT: **24x76.2 M. SPAN TRUSS GIRDER PROPOSED RAIL BRIDGE OVER RIVER GANGA BETWEEN JHUSI AND DARAGANG STATION AT ALLAHABAD (U.P.)**

SCALE:-	1:1	NAME	DATE	TITLE:
DRAWN BY:	A.K.SETH	17.04.23	DETAILS OF C.S.K. BOLTS FOR FIXING PATHWAY, GANGWAY & TROLLEY REFUGE	
CHECKED BY:	S.MJUMDER	17.04.23	B.B.J. SKETCH NO.- 2154-SK-02	
APPROVED BY:			SHEET SIZE:- A4	
B.B.J. ORDER NO.-	2154		REV. 0	

REQN. NO. - D/2351

DATE :- 24.04.2023