

Sketch of property class 10.9 grade, 25.5mm dia T.F. Bolt required for replacing property class 8.8 grade, 24mm dia bolt in Railway X-girder of 29X121.6m span.

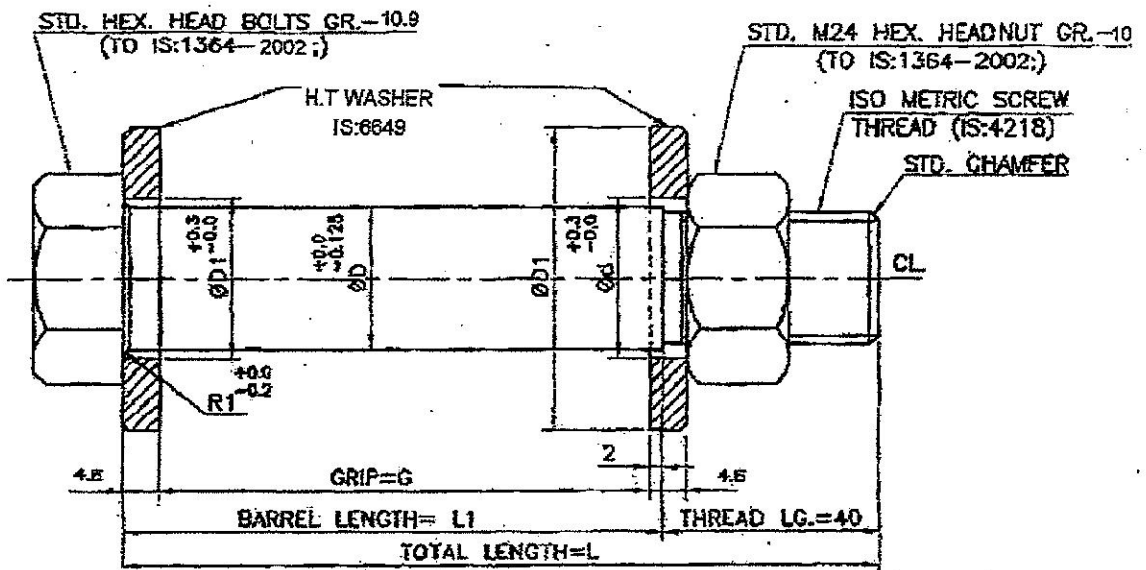

HY TURNED & FITTED BOLTS (GR:10.9) & NUTS (GR:10)

Type	Barrel dia of Bolts "D"	Grip "G"	Barrel Length (L1)	Thread Length	Total Length	Round Washer Outer Dia "D1"	Washer Bore dia (d)	Nos Required /Span	Nos Required for 29 span
1	25.5	85	92	40	132	50	26.52	48	1392
2	25.5	93	100	40	140	50	26.52	72	2088
3	25.5	97	104	40	144	50	26.52	144	4176
4	25.5	111	118	40	158	50	26.52	48	1392
5	25.5	131	138	40	178	50	26.52	64	1856
6	25.5	137	144	40	184	50	26.52	48	1392

- Note:
1. ALL DIMENSION ARE IN MM.
 2. ALL BOLTS ARE GR. 10.9 AND NUTS ARE GR 10 CONFIRMING TO I.S1367 WITH H.T WASHER.
 3. THESE BOLTS ARE REQD. FOR 17X121.6M SPAN TO REPLACE 24 DIA BOLTS.